

IMPORTANT: READ FIRST

This guide contains basic information required to install standard Danver or Brown Jordan Outdoor Kitchens cabinetry. The specifics of the design, configuration, location, space and other factors influencing your project, may require deviations from the stated instructions.

It is recommended that installation be performed by a licensed contractor or other professional with experience installing cabinetry.



Observe Local Building Codes

Local building codes may supersede the information contained within this guide. It is imperative that you understand and adhere to local codes and regulations prior to installing the cabinetry and appliances.

High Wind Areas

If you are installing the cabinetry in a high-wind area, such as a rooftop or in a geographic region that is susceptible to tornados or hurricanes, you are likely required by building code to secure the cabinetry to an immovable structure such as a wall, floor or concrete base.

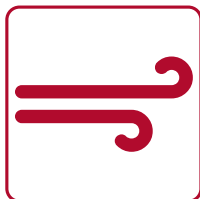

Installation Resources:

For additional resources, such as installation videos, PDF instructions and cleaning guides, visit:

danver.com/resources

brownjordanoutdoorkitchens.com/resources

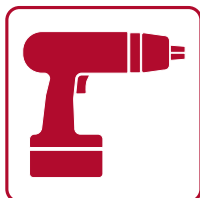

OCP COLUMNS FEATURES

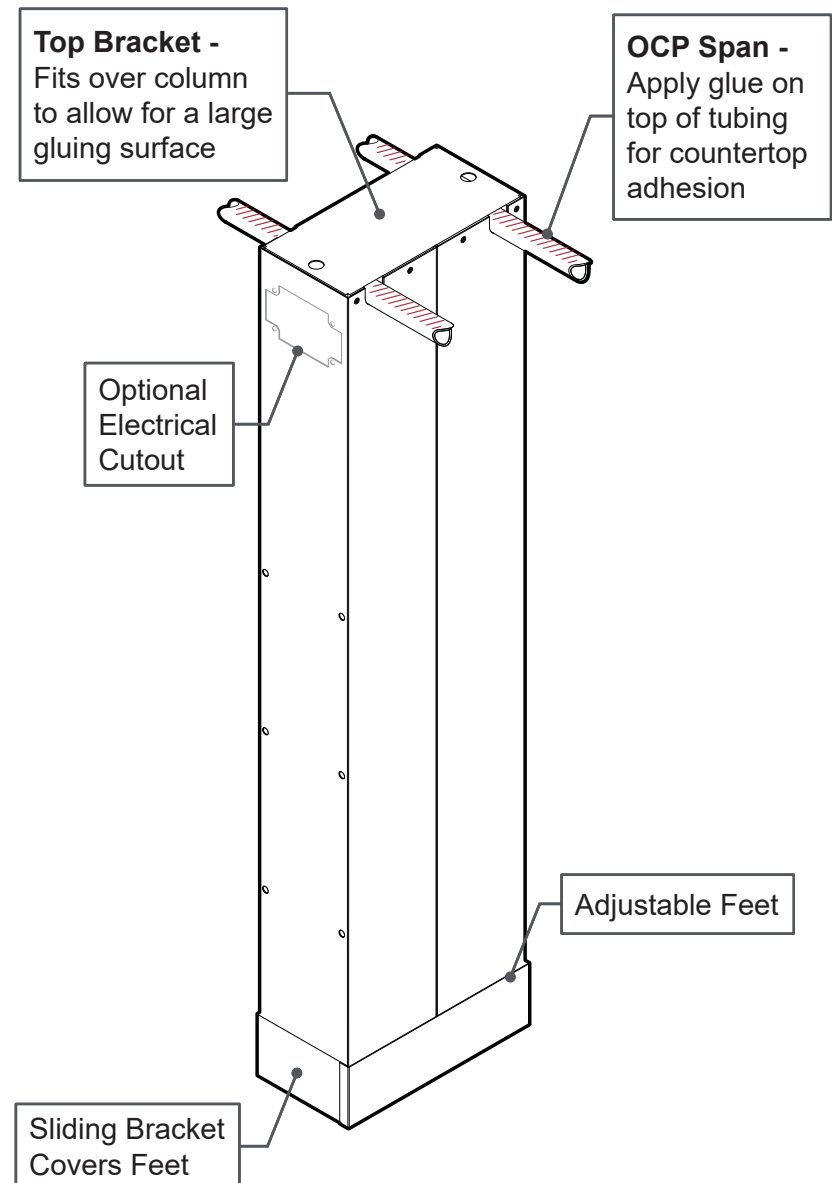

1. Determine placement of the columns behind the cabinets.
2. Use the adjustable feet to maintain correct height.
3. With the OCP column held in position, drill (4) .156" diameter holes in a staggered pattern from inside, through the cabinet or panel into the OCP column.

NOTE: Staggered hole location is not critical and dependent on your cabinet and setup.

4. Remove the OCP column.
5. Enlarge the (4) holes in the cabinet or panel to .200".
6. Reattach the OCP column to the cabinet using the supplied 2.50" long screws. Shorter screws should be used when installing on panels, such as an ORS or OAR.
7. The OCP Spans should be cut so they are centered on the columns. Remove the Top Bracket, Install the OCP Spans. Reinstall the Top Bracket.

