

Danver™

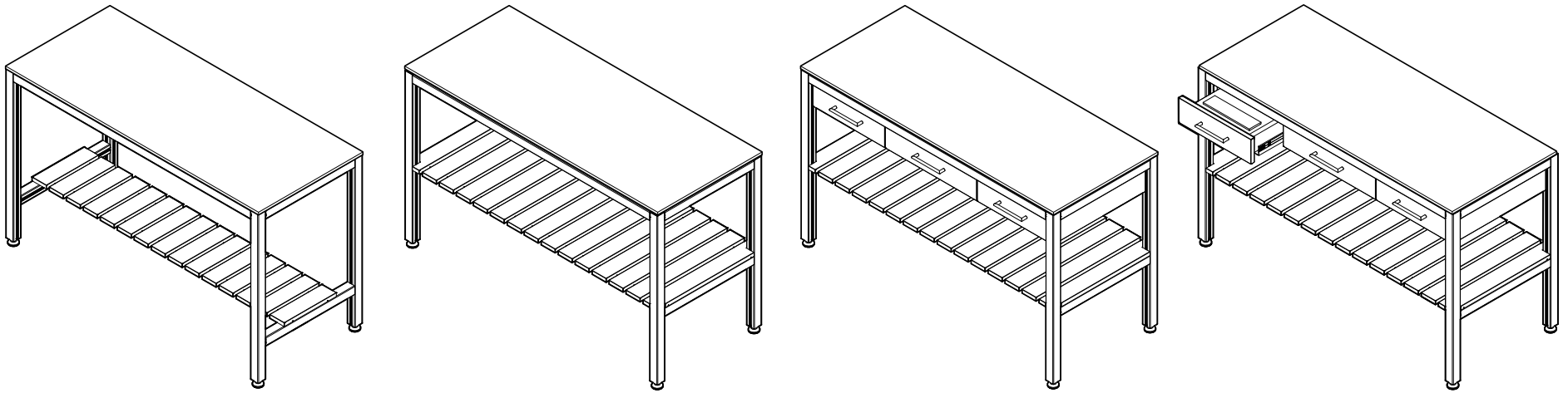

Assembly Guide: Cosmopolitan Table

TABLE OF CONTENTS

IMPORTANT: READ FIRST	3
Stainless Steel Cleaning	3
Assembly: Eat and Prep	4
Assembly: Cook and Store	11
Assembly: ADA Wheelchair Access	22



IMPORTANT: READ FIRST

- DO NOT climb on unit.
- DO NOT step or sit on shelves or drawers.
- Check the parts list to make sure all parts are included and in good condition.
- Read and follow each step carefully. It is very important that each step is performed in the correct order.

Stainless Steel Cleaning

The following are some important tips on cleaning your stainless steel:

- There are a number of reliable stainless steel cleaners on the market
- Use only alkaline, alkaline-chlorinated or non-chloride cleaners
- Avoid hydrochloric acid (muriatic acid) on your stainless steel
- Always use a non-abrasive cleaning tool such as a soft cloth or plastic scouring pad
- Avoid steel pads, wire brushes and scrapers
- Always clean in the direction of the polishing marks by locating the lines or grain and scrub in a motion parallel to them
- If you do end up using a chlorinated cleaner, be sure to rinse thoroughly and dry it, immediately
- Air dry your equipment

Resources

For additional resources, such as installation videos, PDF instructions or cleaning guides, visit: danver.com/resources

Assembly: Eat and Prep

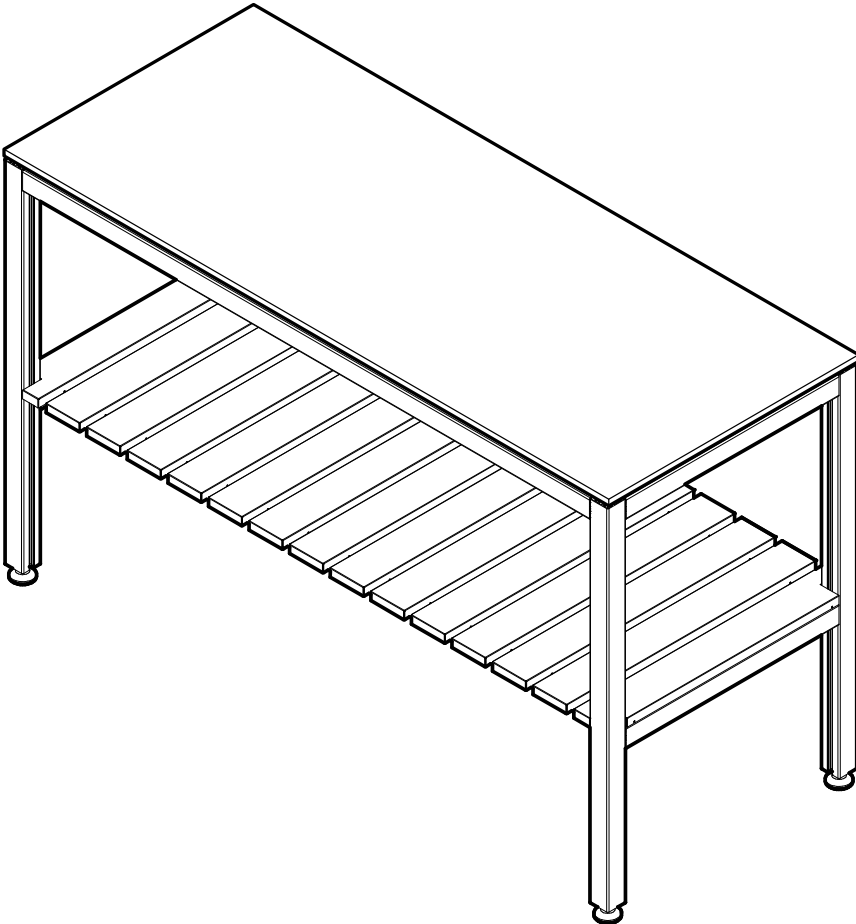
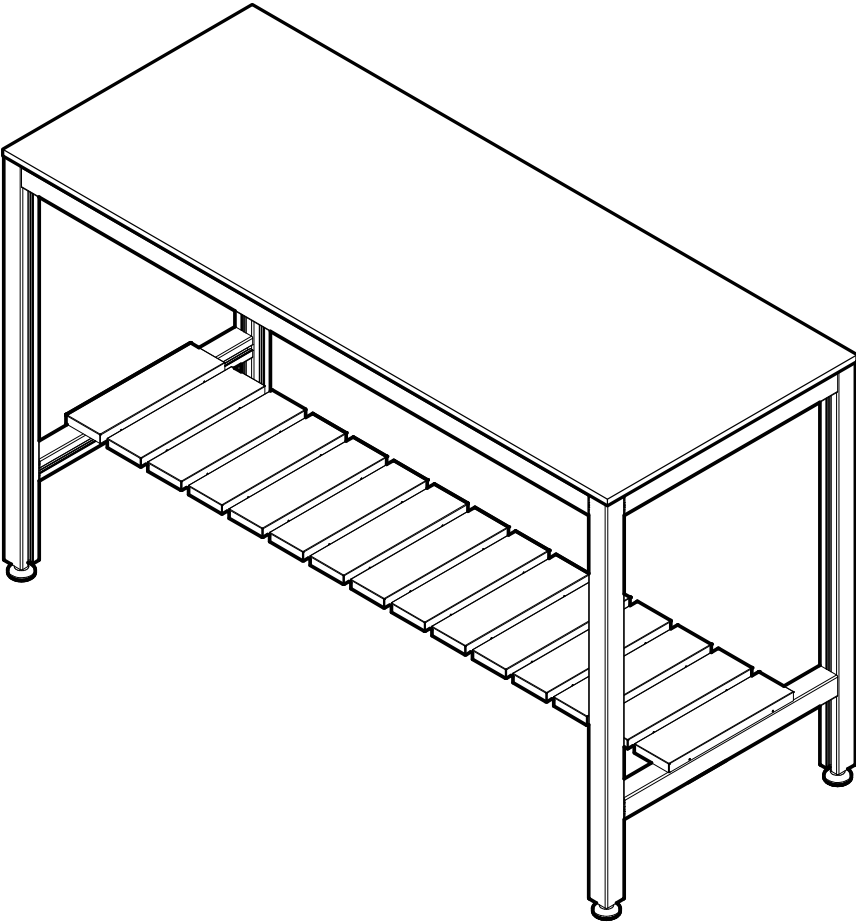

Parts List: Eat and Prep

ITEM	DESCRIPTION	QTY.
A	Counter Top	1
B	Top Frame Assembly	1
C	Shelf Assembly	1
D	Legs	4
E	Glides	4
F	Casters	4

Unboxing

- Remove the leg assemblies (2), set them aside
- Break the corners of the bottom box and lay the sides flat
- Remove the hardware kits and Casters.
- Break the corners of the top box and lay flat to make a work surface.
- Flip top assembly upside down onto the cardboard.

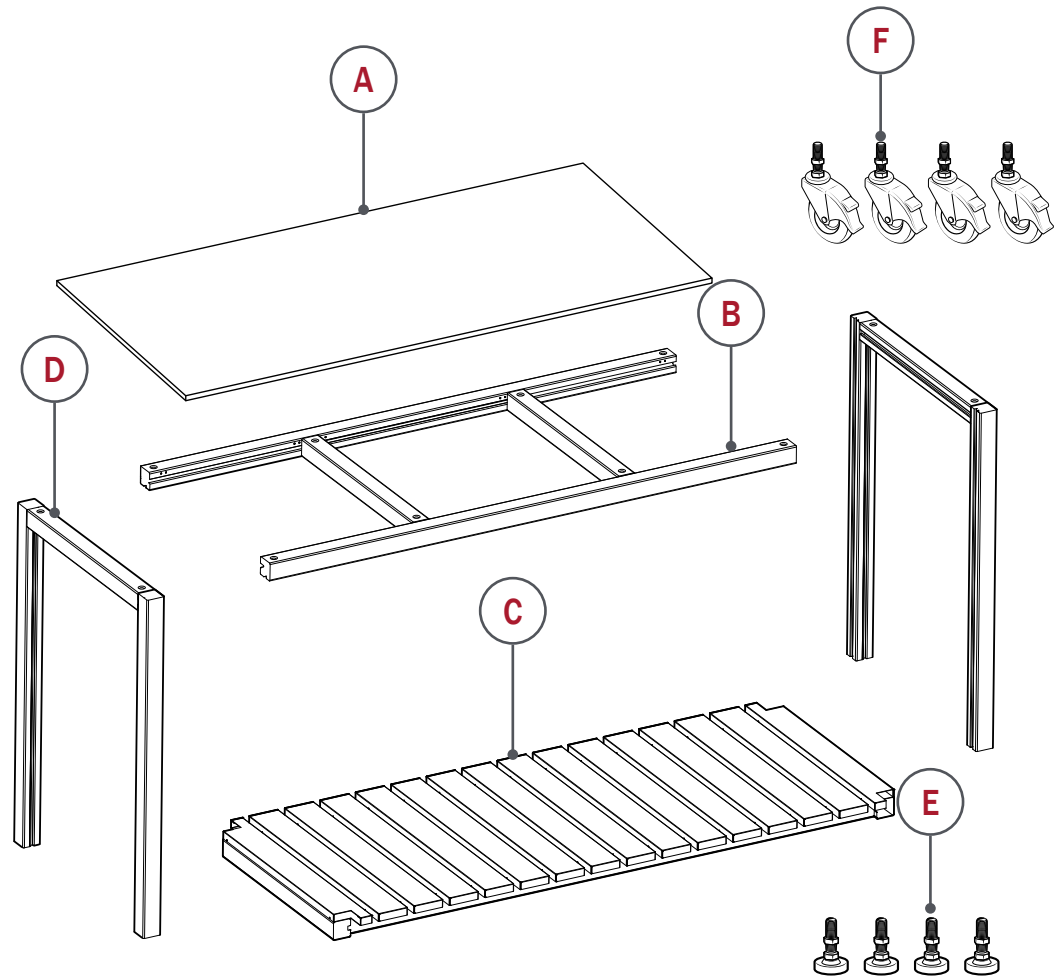

Required Tools:

Power screw driver with #2 Phillips head bit	#2 Phillips head manual screw driver	Level
Allen Wrench (provided)	Adjustable Wrench	

ASSEMBLY: Top Frame Assembly

- 1. Place the Top, face down on a clean, flat protected surface.
- 2. Position the Top Frame Assembly upside down on the cardboard.

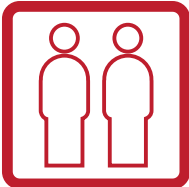

Two people are required for this step

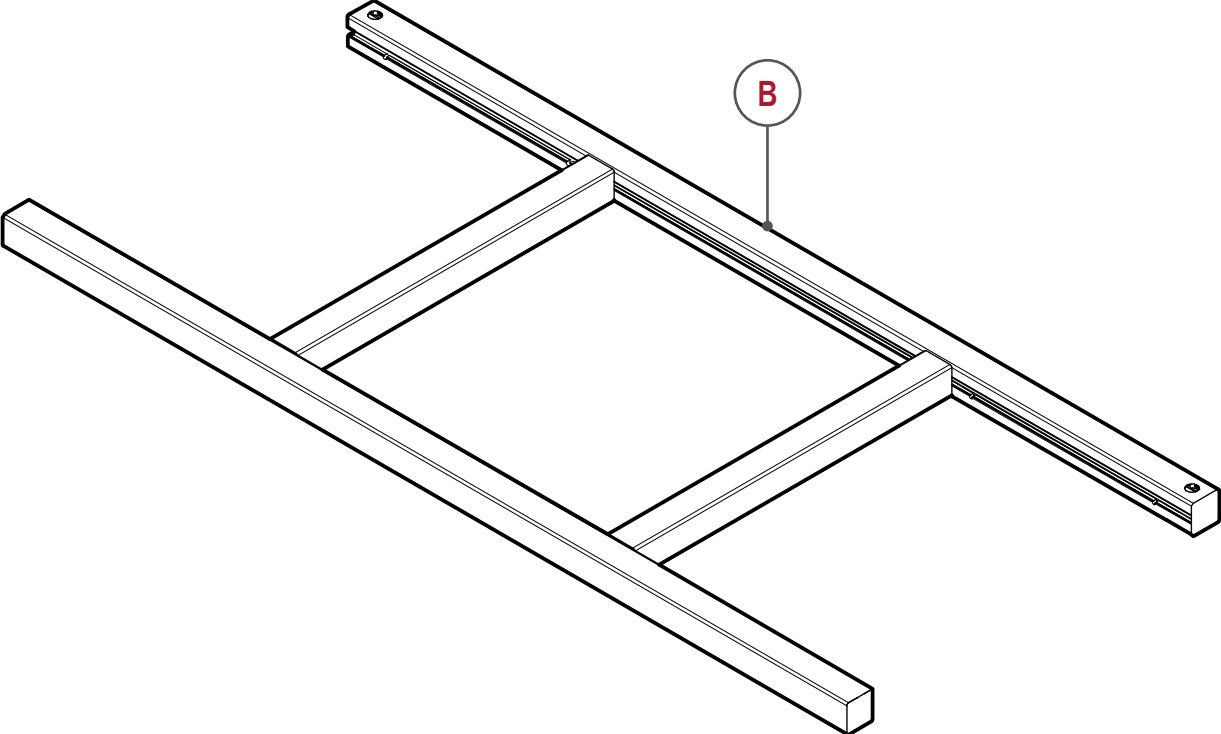

Top Frame Assembly

ASSEMBLY: Glide/Caster Installation

Installation of either the Glide or Caster into the table leg is identical.

1. Screw the Glides (E), or Caster (F) into the threaded end of each leg

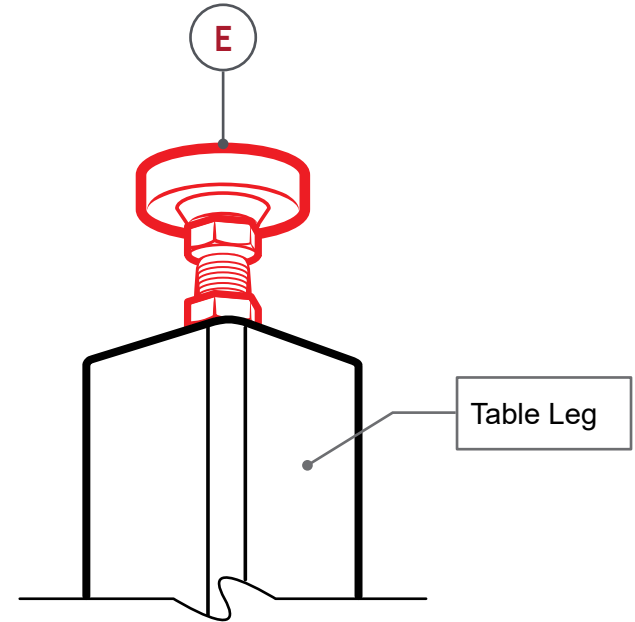

2. Tighten the nut to secure in place using an adjustable wrench.

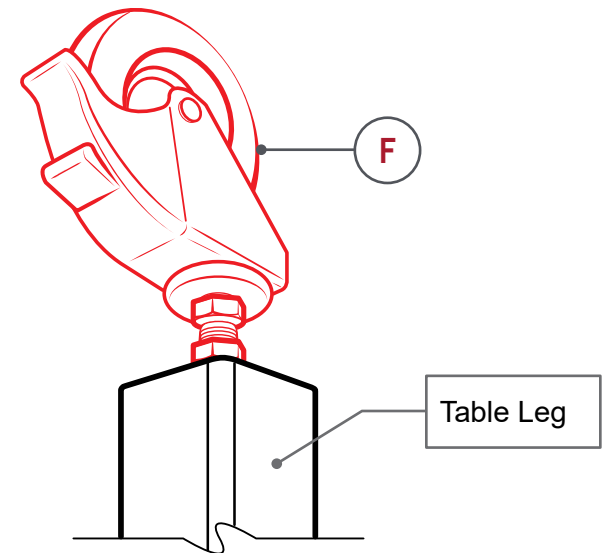

ASSEMBLY: Leg Assembly

1. Make sure the T-bolts on the Top Frame Assy. (B) are pulled out approx. $\frac{1}{4}$ "
2. Align the slots in the leg assembly (D) with the T-bolts on the Top Frame Assy.
3. Insert the T-bolt into the slot. Make sure to align both T-bolts evenly and at the same time
4. Slide the Leg Assy. (D) over T-bolt until level with frame top surface.
5. Tighten the two nuts using the provided Allen wrench.
6. Repeat for each leg.

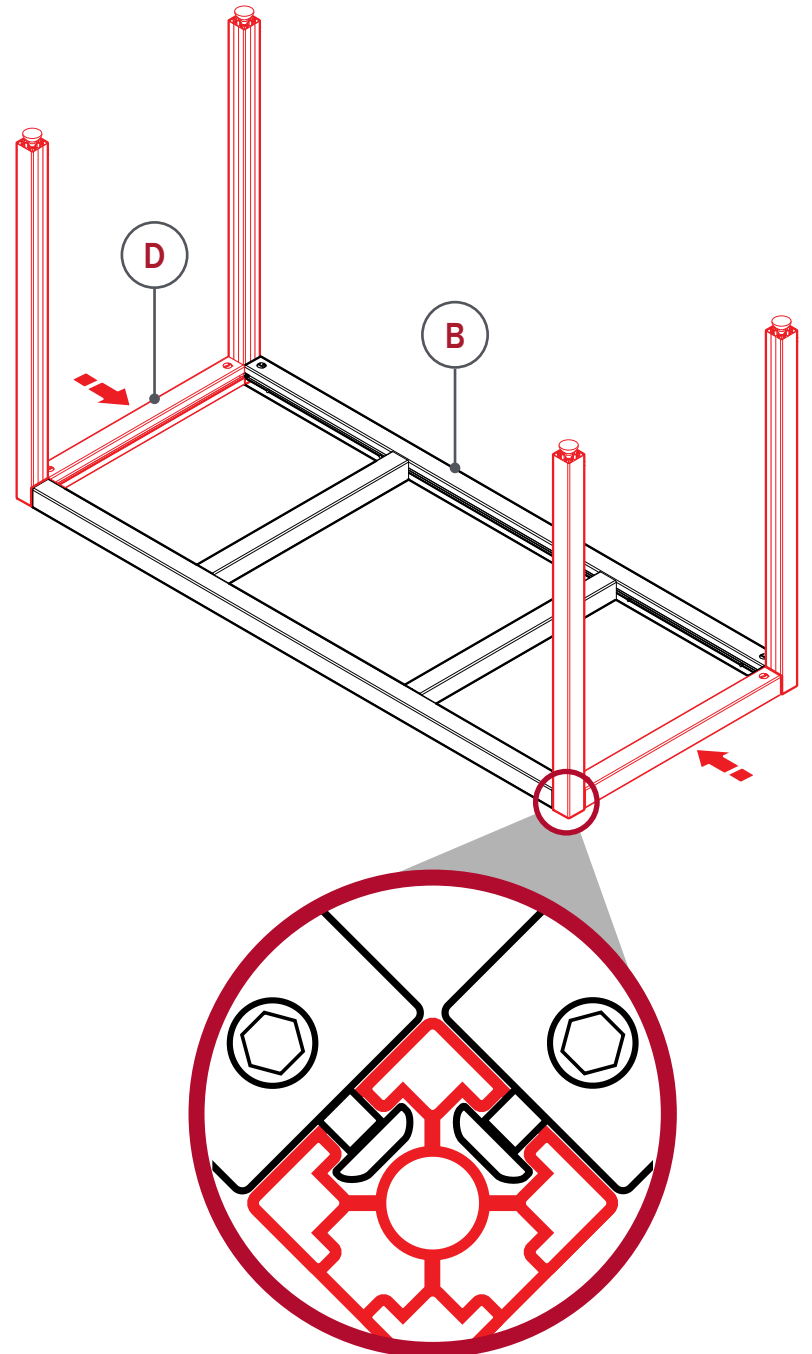

ASSEMBLY: Shelf Assembly

1. Make sure the T-bolts on the Shelf Assy. are pulled out about a $\frac{1}{4}$ ".
2. Position shelf with slats down.
3. Lift the shelf and align the T-bolts of the shelf with the slots in the leg.
4. Insert the T-bolt into the slot. Make sure to align all four T-bolts evenly and at the same time.
5. Slide the shelf down the leg until it rests on the factory installed pins. Make sure to slide both ends evenly and at the same time.
6. Tighten the four nuts using the provided Allen wrench.

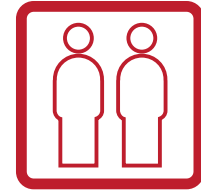

Two people are required for this step

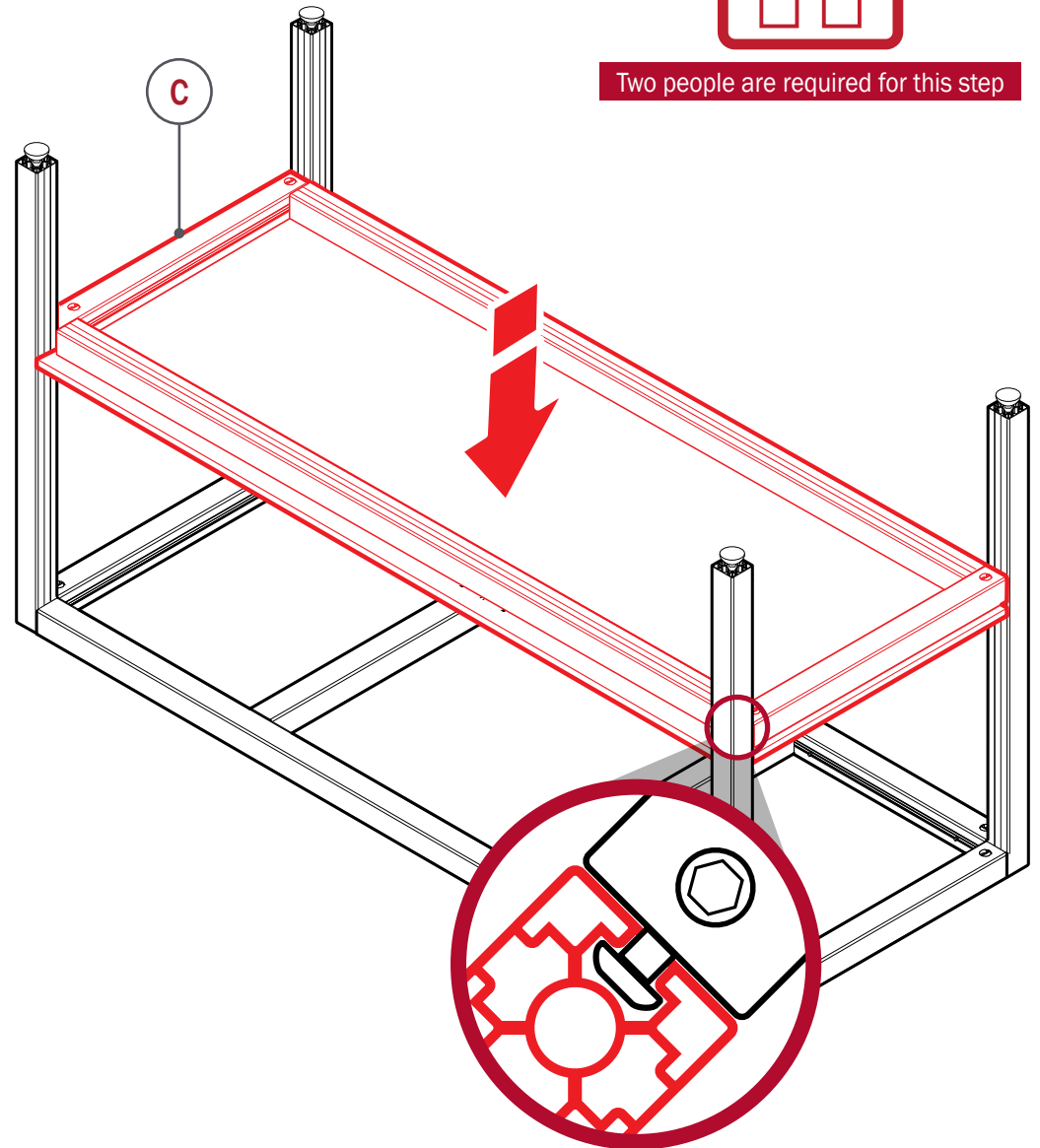

ASSEMBLY & INSTALLATION: Counter Top

1. Turn table over to rest on the legs.
2. Place countertop box on flat surface.
3. Open box and remove double sided tape.
4. Remove backing from tape and place one piece on top of all four rails for the Top Frame Assy.
5. Lift countertop and position on frame. Make sure to evenly space the overhang on each side of the table.
6. Level the finished table by adjusting the glides to the desired height.
7. Tighten locking nut on each glide.



Two people are required for this step

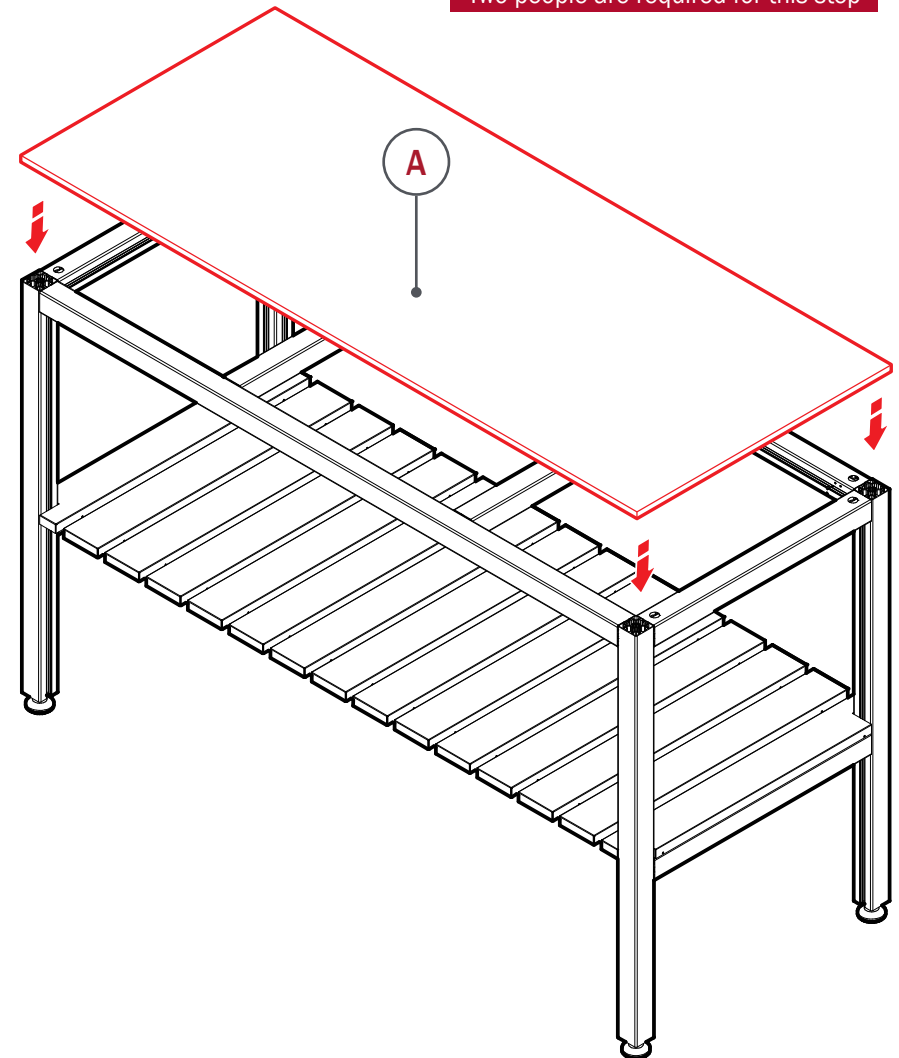

Assembly: Cook and Store

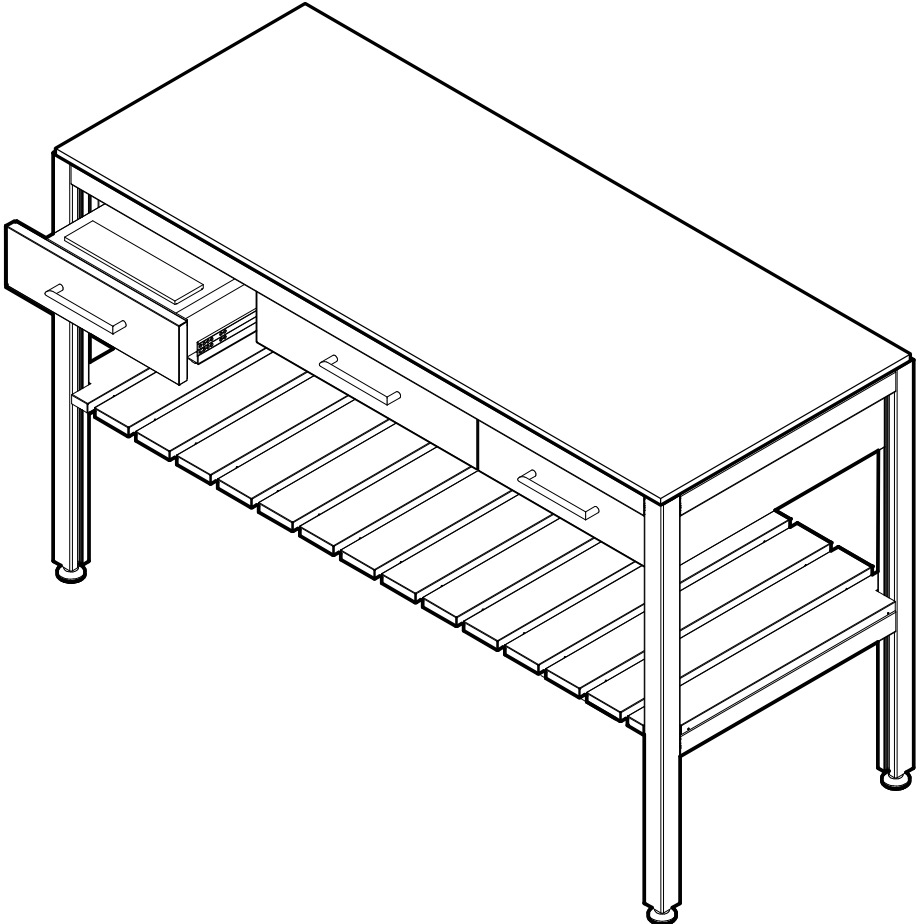
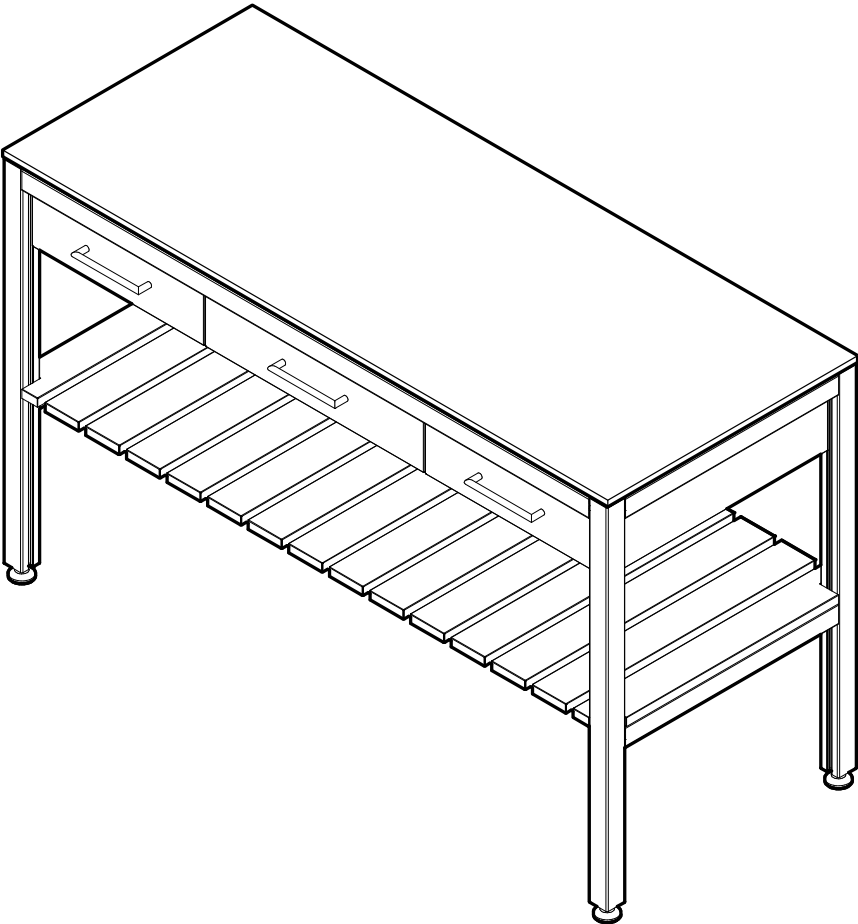

Parts List: Cook and Store

ITEM	DESCRIPTION	QTY.
A	Counter Top	1
B	Top Frame Assembly	1
C	Shelf Assembly	1
D	Legs	4
E	Glides	4
F	Rear Panel	1
G	Side Panel	2
H	Casters	4

Unboxing

- Remove the leg assemblies (2), set them aside
- Break the corners of the bottom box and lay the sides flat.
- Remove the hardware kits and Casters.
- Remove the outside panels (3 panels: 2 end & 1 back), set them aside.
- Remove packing foam from inside of the drawers and remove the drawers.
- Break the corners of the top box and lay flat to make a work surface.
- Flip top assembly upside down onto the cardboard.

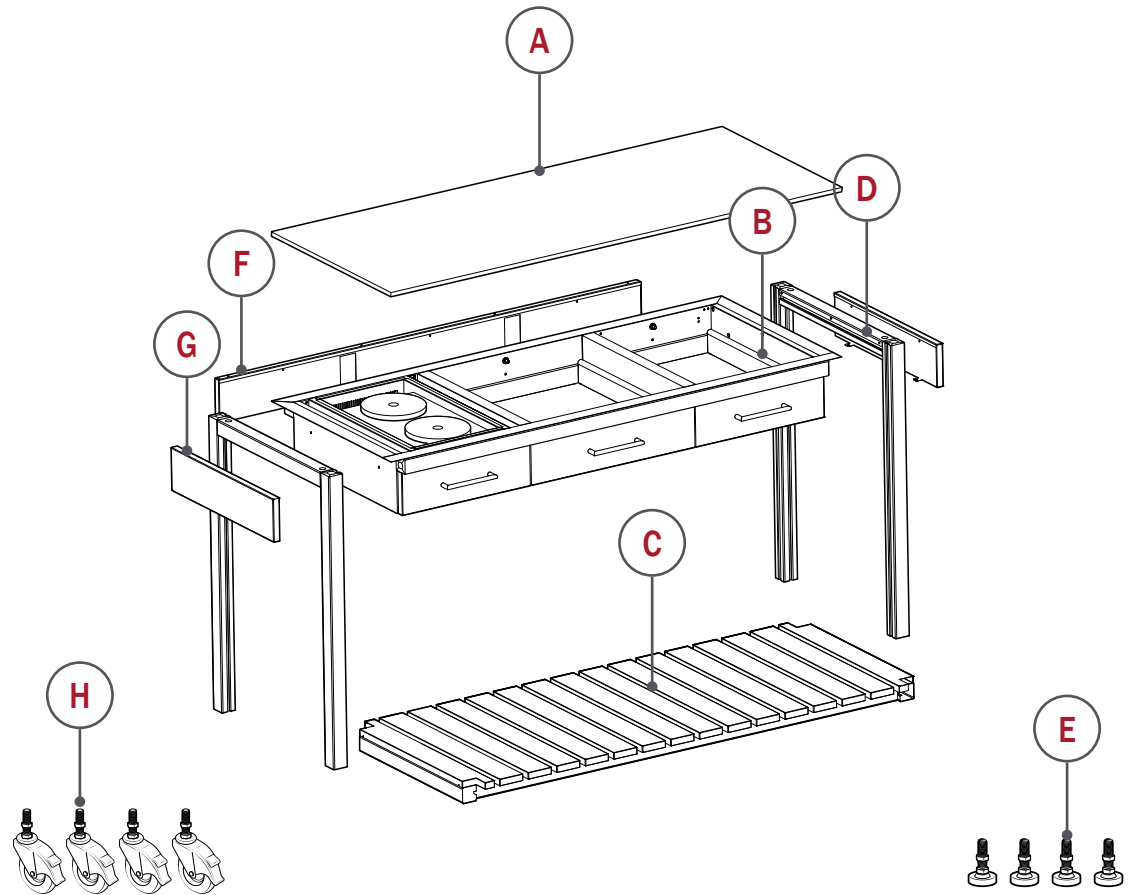

Required Tools:

Power screw driver with #2 Phillips head bit	#2 Phillips head manual screw driver	Level
Allen Wrench (provided)	Adjustable Wrench	

ASSEMBLY: Glide/Caster Installation

Installation of either the Glide or Caster into the table leg is identical.

1. Screw the Glides (E), or Caster (H) into the threaded end of each leg.

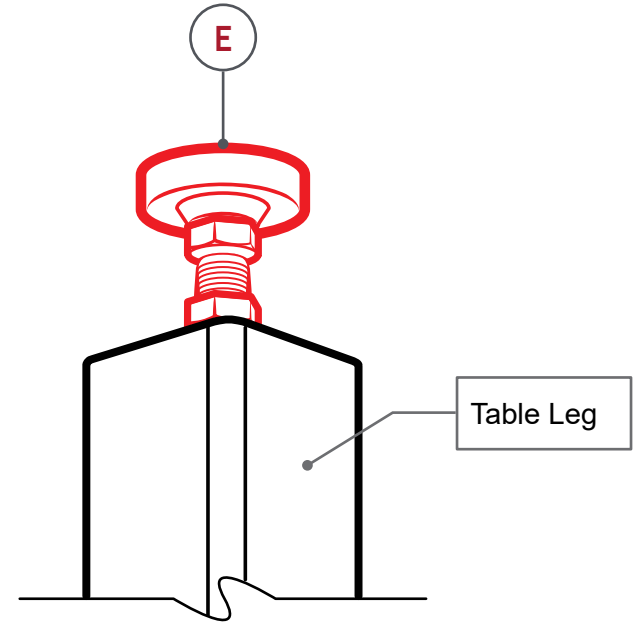

2. Tighten the nut to secure in place using an adjustable wrench.

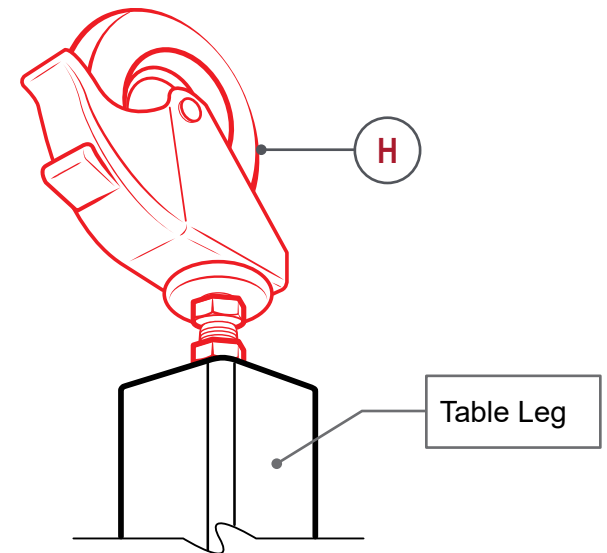

ASSEMBLY: Leg Assembly

1. Make sure the T-bolts on the Top Frame Assy. (B) are pulled out approx. $\frac{1}{4}$ ".
2. Align the slots in the leg assembly (D) with the T-bolts on the Top Frame Assy.
3. Insert the T-bolt into the slot. Make sure to align both T-bolts evenly and at the same time.
4. Slide the Leg Assy. (D) over T-bolt until level with frame top surface.
5. Tighten the two nuts using the provided Allen wrench.
6. Repeat for each leg.

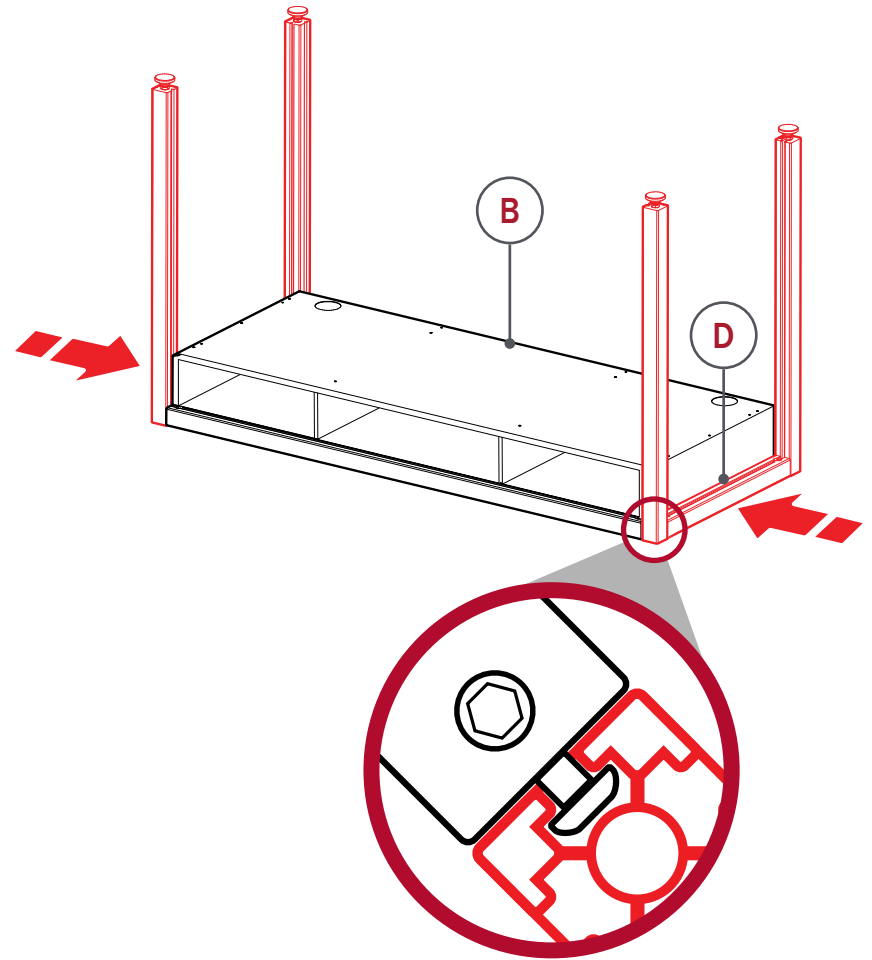

ASSEMBLY: Side Panels

1. Position the side panels (G) , aligning the two tabs with the mounting holes.

2. Install two (2) # 10 self tapping screws.

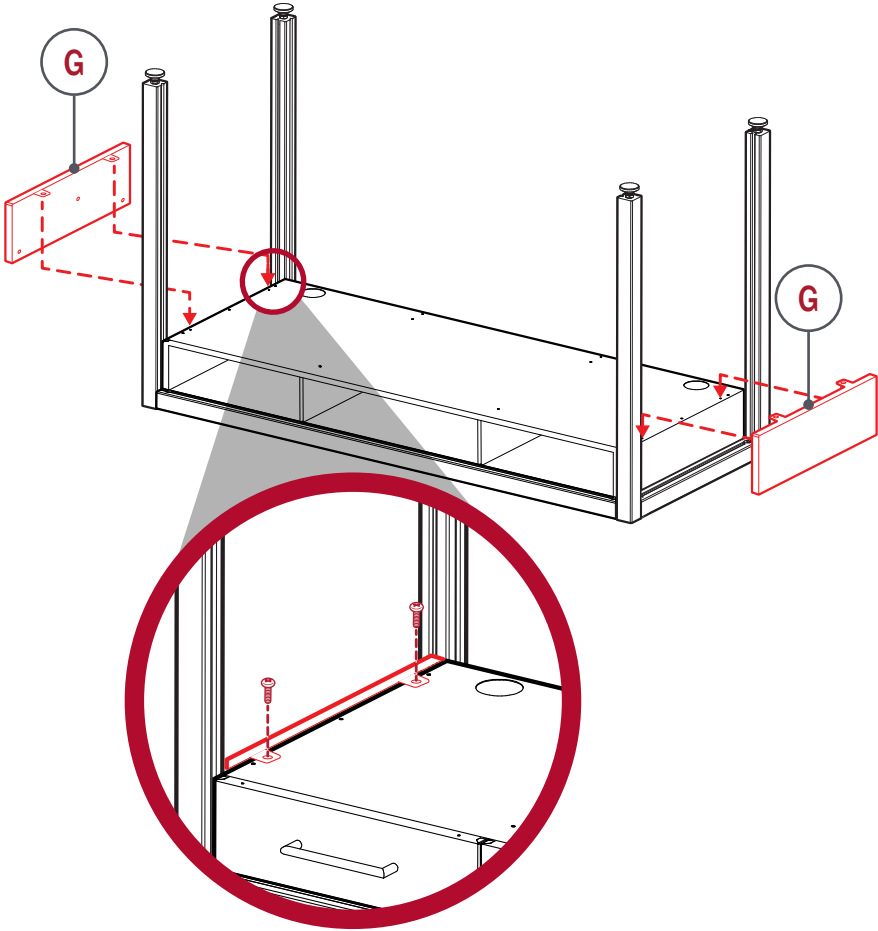

ASSEMBLY: Back Panels

1. Position the back panel (F), aligning the two tabs with the mounting holes.

2. Install two (2) # 10 self tapping screws.

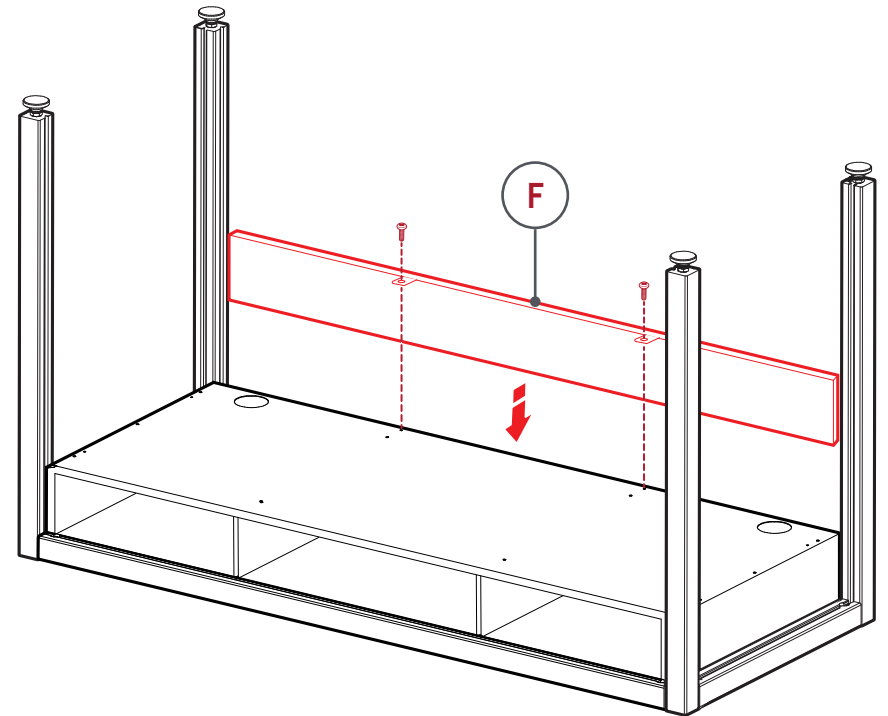

ASSEMBLY & INSTALLATION: Shelf Assembly

1. Make sure the T-bolts on the Shelf Assy. are pulled out about a $\frac{1}{4}$ ".

2. Position the shelf assembly (C) with slats down.

3. Lift the shelf and align the T-bolts of the shelf with the slots in the leg.

4. Insert the T-bolt into the slot. Make sure to align all four T-bolts evenly and at the same time.

5. Slide the shelf down the leg until it rests on the factory installed pins. Make sure to slide both ends evenly and at the same time.

6. Tighten the four nuts using the provided Allen wrench.



Two people are required for this step

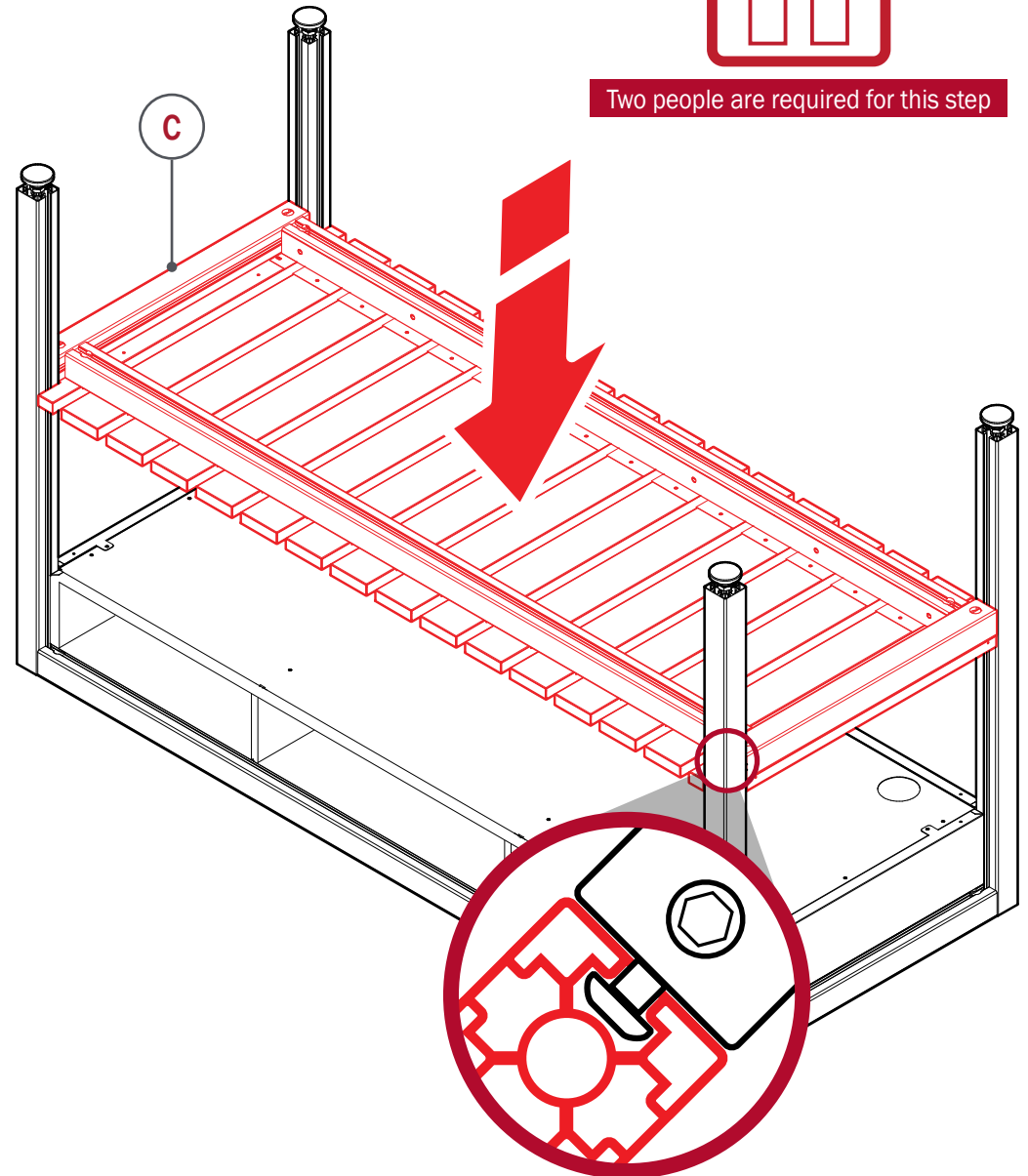

ASSEMBLY & INSTALLATION: Side & Rear Panel

1. Turn table over to rest on the legs.

2. Install five (5) #10 self tapping screws on the left side panel.

3. Install five(5) #10 self tapping screws on the right side panel.

4. Install three (3) #10 self tapping screws on the rear panel.



Two people are required for this step

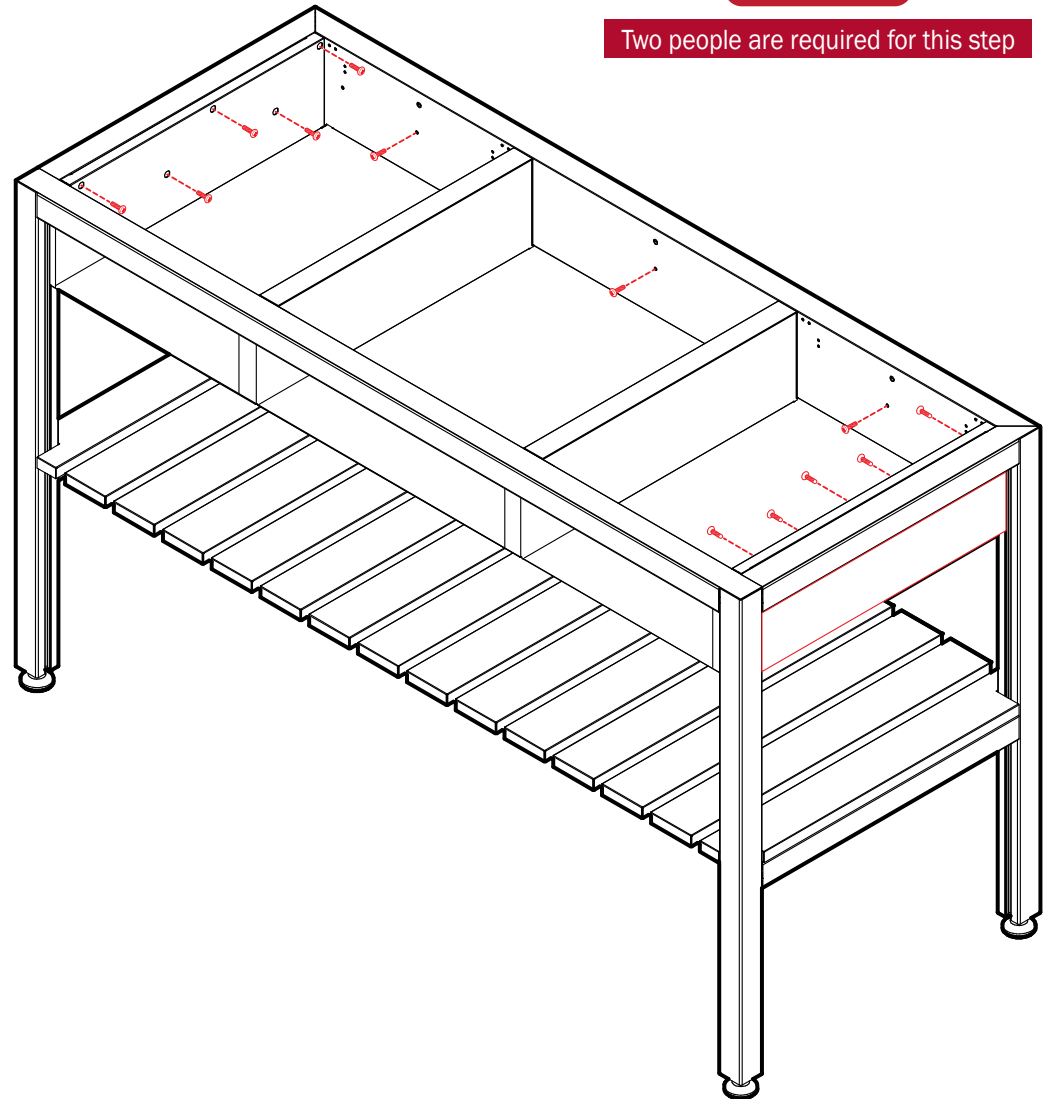

ASSEMBLY: Reinstallation of Drawers

1. Rest the back of the drawer on the slide mid-way back.

2. Lay drawer flat on slide and push into place until bottom clips are engaged.

NOTE: If using the Invisacook system, leave the drawer for the Invisacook Controller out for this step.

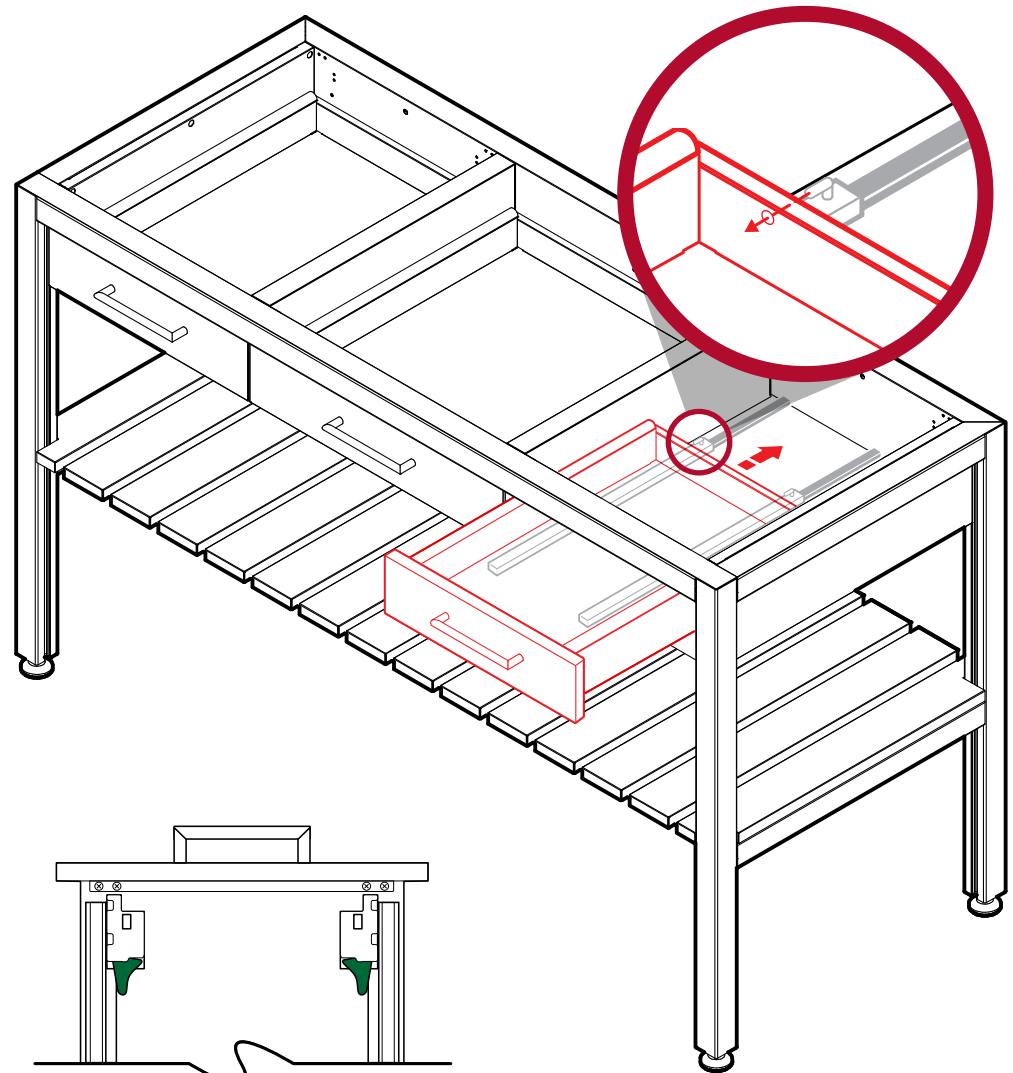

Drawer Latch Detail

ASSEMBLY & INSTALLATION: Invisacook™

The Invisacook induction system can be installed in either the left or right hand side of the top frame assembly. Simply install the Controller Drawer in the preferred side.

1. Install the Invisacook Brace into the Drawer Assembly area (either left or right hand side) and secure in place using eight (8) #10 screws.
2. Drop the Invisacook Burner into the Brace.
3. Route the power cord through the corner opening in the top Frame Assembly.
4. Snap the Invisacook Controller into the drawer.
5. Connect the Invisacook Burner to the Controller. See the Invisacook instructions included with the system.

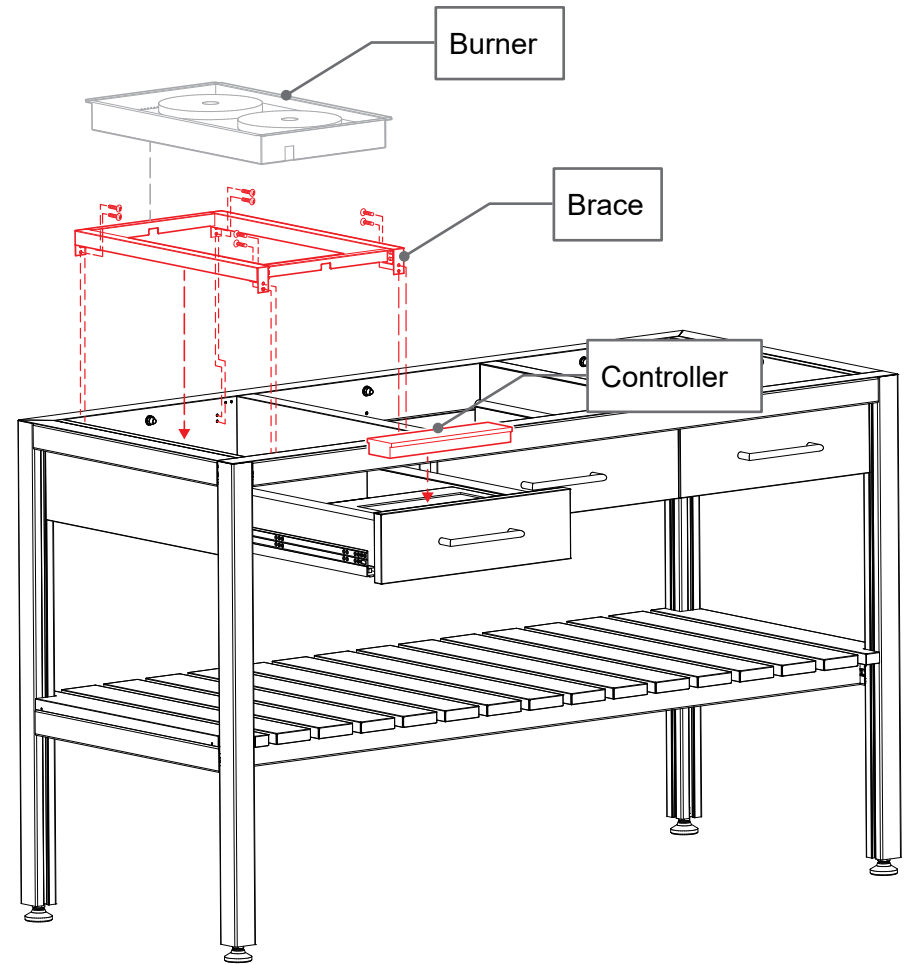

ASSEMBLY & INSTALLATION: Countertop

1. Place countertop box on flat surface.
2. Open box and remove double sided tape.
3. Remove backing from tape and place one piece on top of all four rails for the Top Frame Assy.
4. Lift countertop (C) and position on frame. Make sure to evenly space the overhang on each side of the table.
5. Level the finished table by adjusting the glides to the desired height.
6. Tighten the locking nut on each glide.

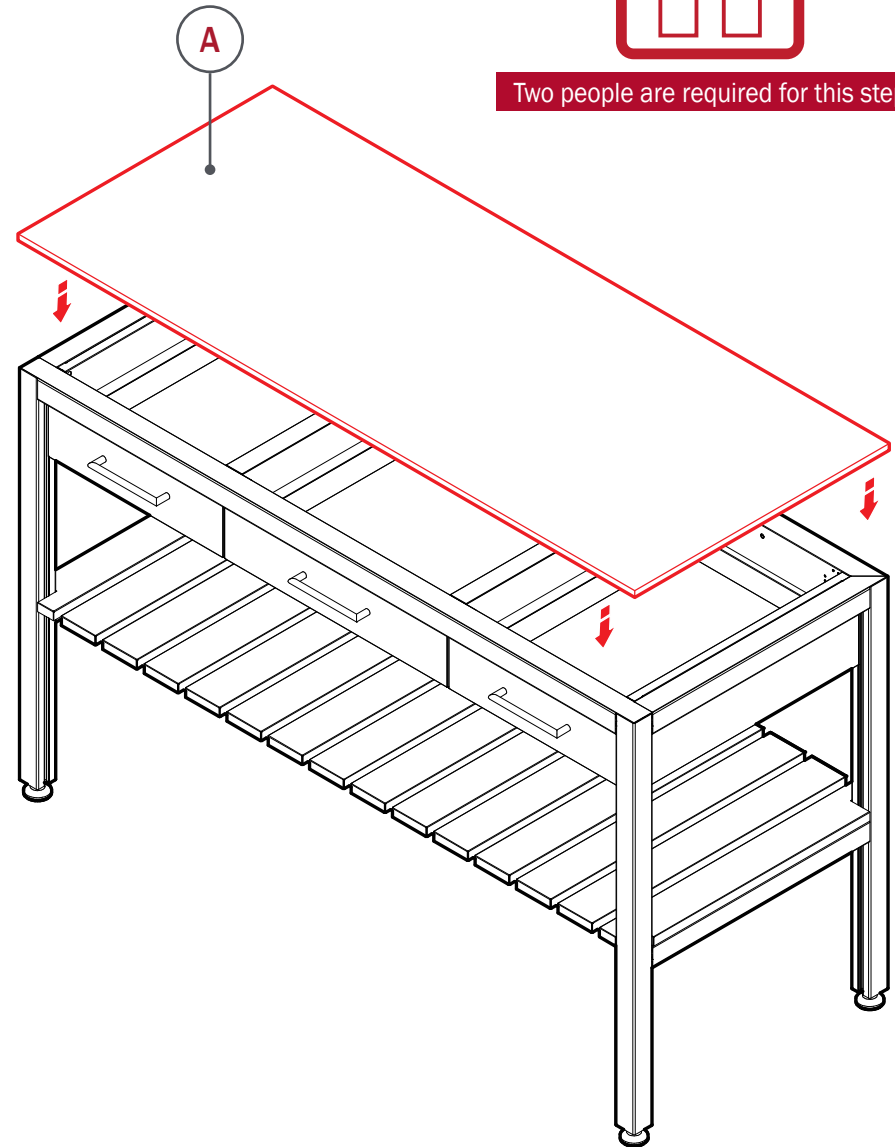

Assembly: ADA Wheelchair Access

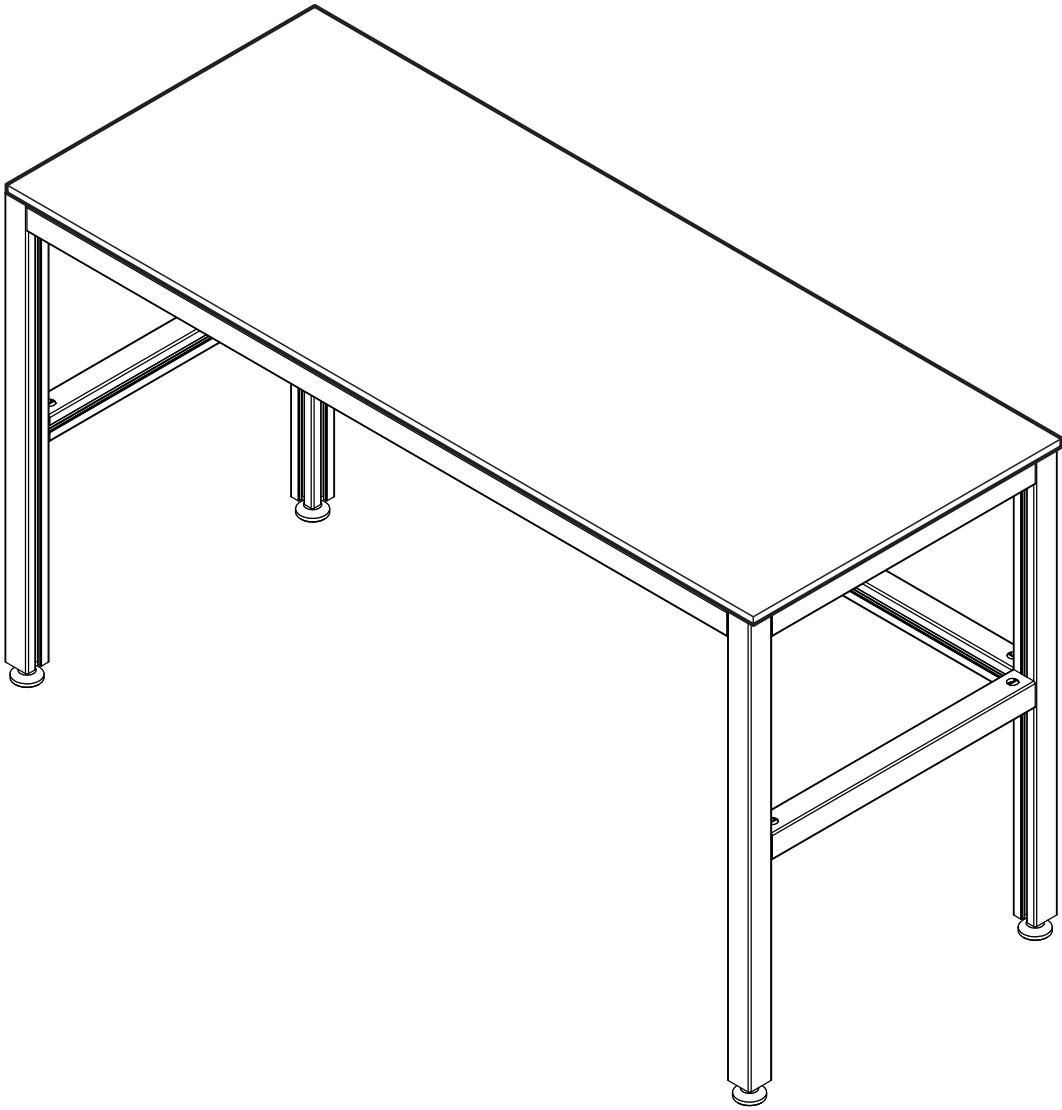

Parts List: ADA Wheelchair Access

ITEM	DESCRIPTION	QTY.
A	Counter Top	1
B	Top Frame Assembly	1
C	Bottom Support Bar	1
D	Legs	4
E	Glides	4

Unboxing

- Remove the leg assemblies (2) and bottom support bar, set them aside
- Break the corners of the bottom box and lay the sides flat
- Remove the hardware kits.
- Break the corners of the top box and lay flat to make a work surface.
- Flip top assembly upside down onto the cardboard.

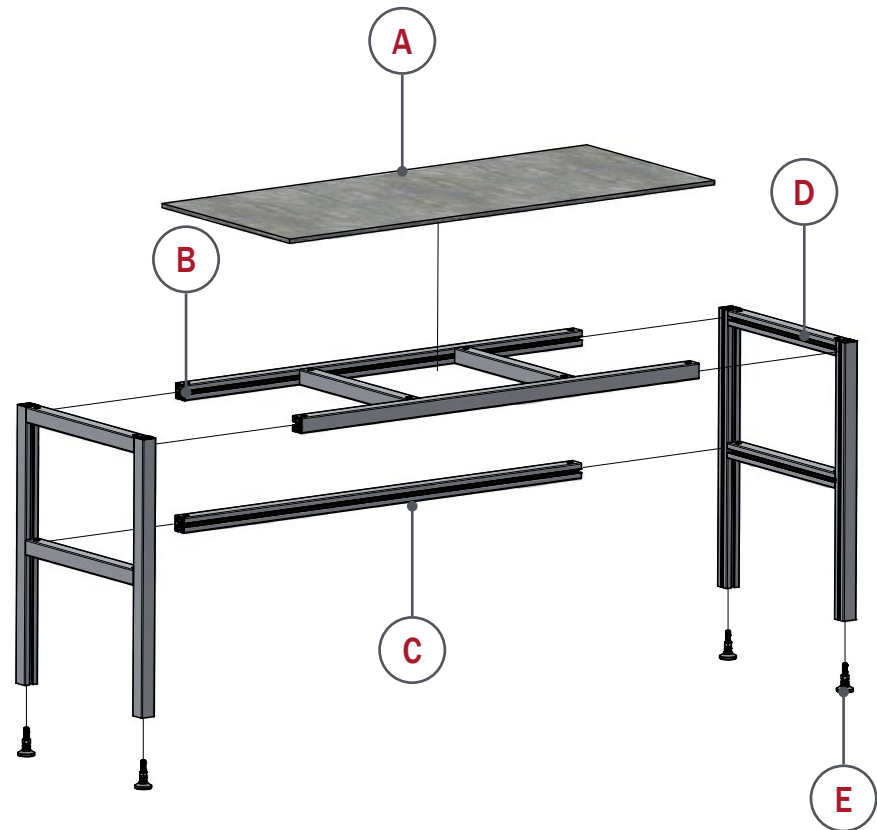

Required Tools:

Power screw driver with #2 Phillips head bit	#2 Phillips head manual screw driver	Level
Allen Wrench (provided)	Adjustable Wrench	

ASSEMBLY: Top Frame Assembly

1. Place the Top, face down on a clean, flat protected surface.
2. Position the Top Frame Assembly upside down on the cardboard.

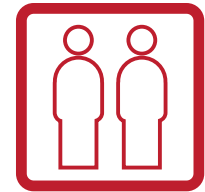

Two people are required for this step

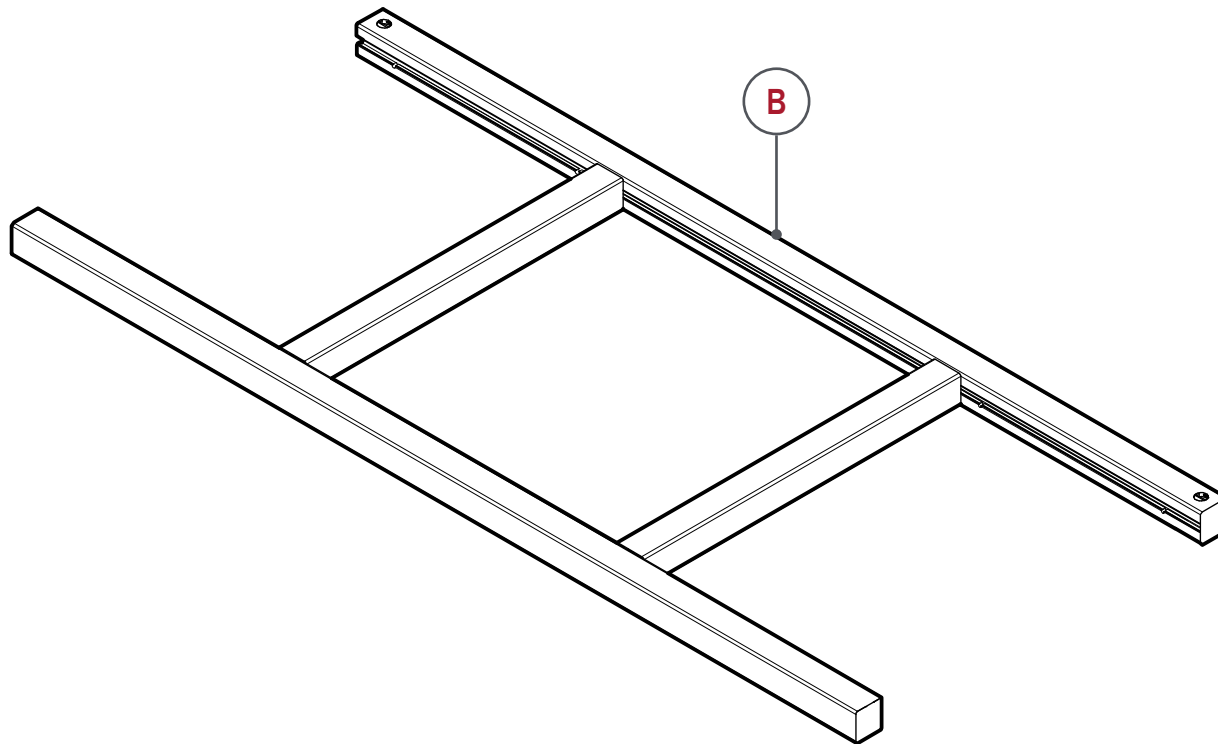

ASSEMBLY: Glide Installation

1. Screw the Glides (E) into the threaded end of each leg

2. Tighten the nut to secure in place using an adjustable wrench.

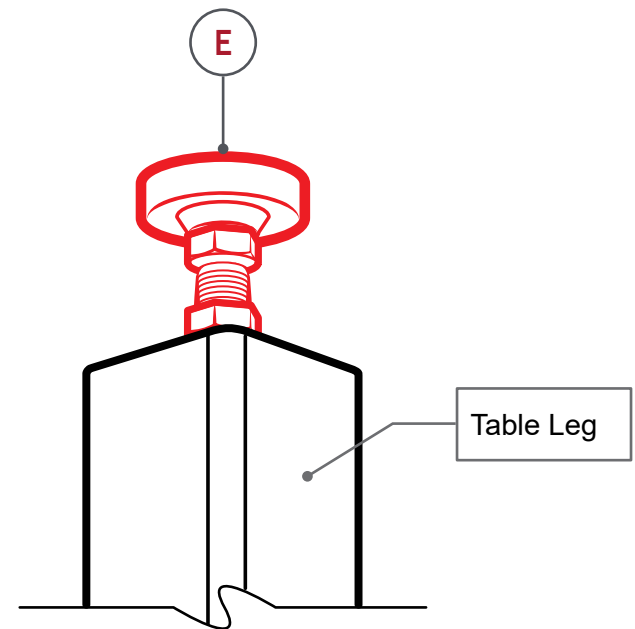

ASSEMBLY: Leg Assembly

1. Make sure the T-bolts on the Top Frame Assy. (B) are pulled out approx. $\frac{1}{4}$ "
2. Align the slots in first leg assembly (D) with the T-bolts on the Top Frame Assy.
3. Insert the T-bolt into the slot. Make sure to align both T-bolts evenly and at the same time
4. Slide the Leg Assy. (D) over T-bolt until level with frame top surface.
5. Tighten the two nuts using the provided Allen wrench.
6. Next connect Bottom Support Bar (C) to installed leg assembly.
7. Lastly, Repeat Steps 1-6 for other leg assembly

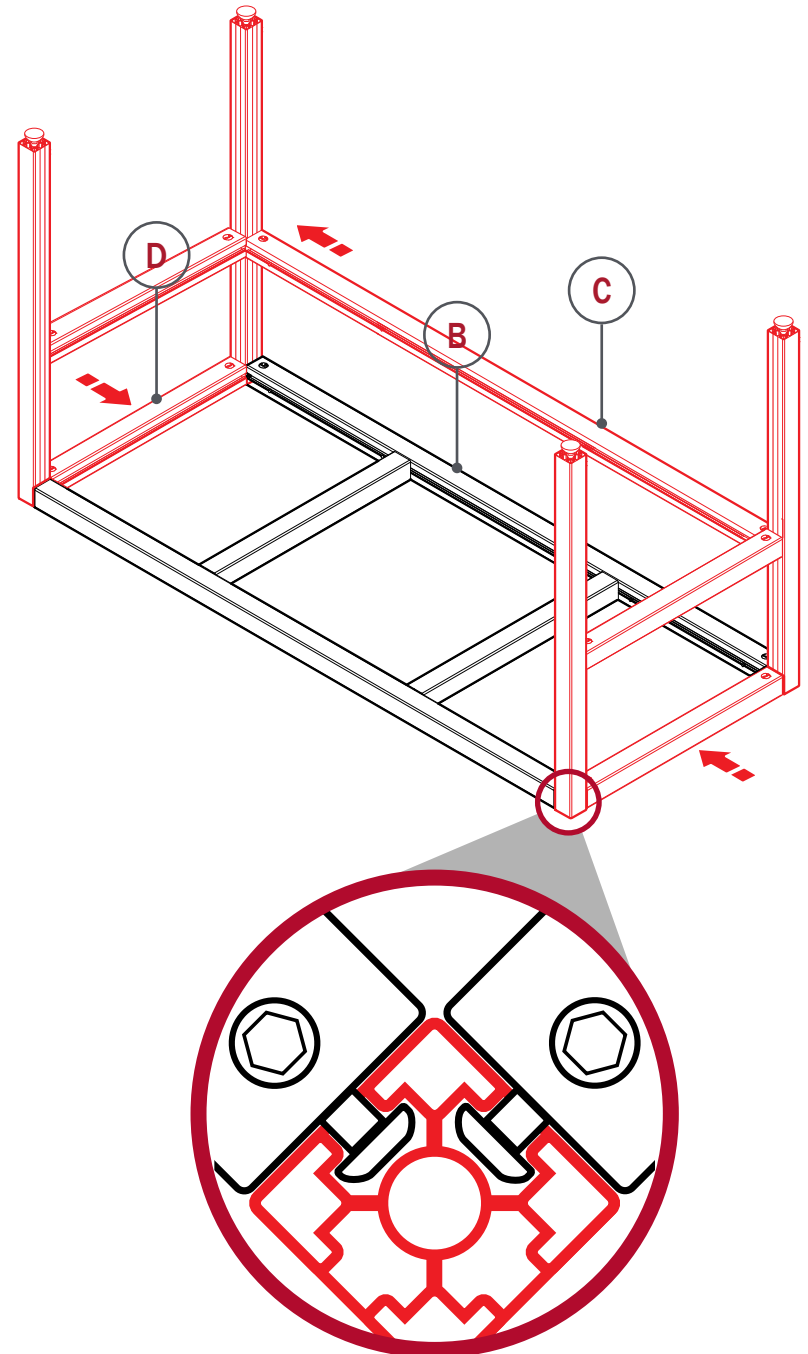

ASSEMBLY & INSTALLATION: Counter Top

1. Turn table over to rest on the legs.

2. Place countertop box on flat surface.

3. Open box and remove double sided tape.

4. Remove backing from tape and place one piece on top of all four rails for the Top Frame Assy.

5. Lift countertop and position on frame. Make sure to evenly space the overhang on each side of the table.

6. Level the finished table by adjusting the glides to the desired height.

7. Tighten locking nut on each glide.



Two people are required for this step

